

J3C-S Series

24-240V Multi-Voltage Smart Electric Actuator

Models S20, S35, S55 & S85



J3C-S USER FRIENDLY ON-OFF ELECTRIC ACTUATOR
WITH MULTI-COLOURLED LED STATUS LIGHT AND ALL
EXTERNAL ELECTRICAL CONNECTIONS

Accepts J+J quick and easy to install plug & play function conversions kits to become:

J3C-S FAILSAFE ELECTRIC ACTUATOR WITH BSR KIT INSTALLED

J3C-S MODULATING ELECTRIC ACTUATOR WITH DPS KIT INSTALLED

J3C-S FAILSAFE MODULATING ELECTRIC ACTUATOR WITH BOTH KITS INSTALLED

J+J

 **Installation & Operation Manual**

I O M S

ISO 9001:2015 Accredited Company

Tel: +44(0)1386 552369

Fax: +44(0)1386 554227

sales@allvalves.co.uk

www.allvalves.co.uk

Allvalves Online Ltd, Automation House, Unit 2, Pershore, WR10 2DF UK

INDEX

Page	Details	Page	Details
1	Front cover	5	Explanation of the different functions available
2	Index, Structure, Principle of Operation, ID label	6	Direction of rotation, position indicators, working quadrant
3	Safety instructions, Warranty, External Connectors	7	LED light, manual override, torque limiter
4	Wiring diagrams for on-off, failsafe and modulating	8	Mounting, weatherproof rating, recycling, support

STRUCTURE OF J3C QUARTER TURN ELECTRIC VALVE ACTUATORS



The J3C range of electric actuators are simply a gearbox, a motor and a complex electronic circuit board containing a small computer chip, and are designed so that in normal circumstances there are no internal adjustments that need to be made and that as all electrical connections are external and the connecting plugs are supplied with the actuator, there is no need to remove the actuator's cover to connect them. Inside the actuator there are no terminal strips, dip switches or jumpers that are usually common in this type of product. The J3C is a maintenance free product.

Therefore removing the actuator's cover may invalidate the warranty. If you feel you need to remove the cover, please check with the manufacturers' agent BEFORE removing the cover.

PRINCIPLE OF OPERATION

The standard function of a J3C electric valve actuator is power open, power close. It stays put on mains power failure. On receipt of a continuous power signal, the motor runs and via a planetary gearbox system, rotates the output shaft. The motor is stopped by internal cams, fitted to the output shaft, striking micro-switches which cuts power to the motor. When a subsequent continuous reversing signal is received, the motor will turn in the opposite direction, reversing the direction of rotation of the output shaft. The actuator can be jog controlled by switching the power on to start and off to stop. Be aware that during the 'off' period the anti-condensation heater is de-energised. As we provide anti-condensation protection, damage caused by condensation is **not covered by the manufacturers' warranty**.

Uniquely the J3C can have this standard functionality changed by installing user friendly plug and play kits, to create failsafe, modulating and failsafe modulating functionality.

IDENTIFICATION LABEL

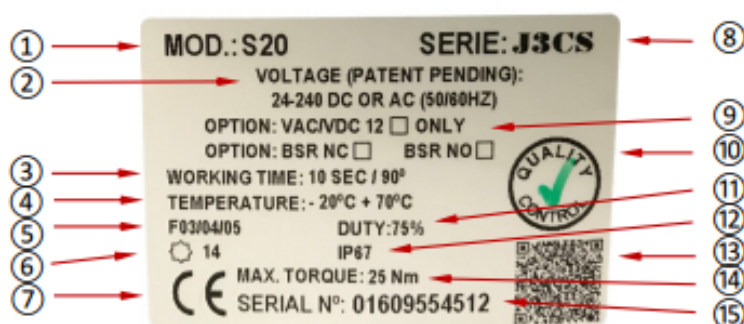

Item	Detail
1	Actuator Model number
2	Working voltage range
3	Run time for specified angle
4	Ambient temperature range
5	ISO5211 Mounting options
6	Output drive size (female star)
7	CE Mark
8	Type/ Series of J+J electric actuator
9	Function change check boxes
10	Factory quality check mark
11	Motor duty cycle rating
12	Ingress protection rating
13	Factory QR code (internal use only)
14	Maximum break away torque
15	Date coded actuator serial number



DO NOT remove the ID label from the actuator. Removal prevents us from being able to identify the actuator and therefore the removal of any labels instantly invalidates the manufacturers' warranty irrespective of the supply date of the J3C.

ISO 9001:2015 Accredited Company

Tel: +44(0)1386 552369

Fax: +44(0)1386 554227

sales@allvalves.co.uk

www.allvalves.co.uk

Allvalves Online Ltd, Automation House, Unit 2, Pershore, WR10 2DF UK

SAFETY INSTRUCTIONS



Damage caused by non-compliance to these instructions will not be covered by our warranty. It is essential therefore that you read these instructions **BEFORE** installing or connecting the actuator.

SAFETY INSTRUCTIONS



J+J Electric actuators operate with the use of live electricity. It is recommended that only qualified electricians or people instructed in accordance with electrical engineering, and familiar with local health and safety directives, be involved in the connection of these actuators. It is strongly recommended that each actuator has its own independent fused power supply system to protect it against the influence of other electrical devices connected to the system.

WARRANTY INFORMATION

WARRANTY INFORMATION

> Every J+J electric actuator is fully tested and set at the factory, they will not normally require adjustment on site.



>The J+J electric actuator range is guaranteed for 12 months from date of despatch from the manufacturer against all types of manufacturing and material defects. Actuators that have failed due to faulty materials will be replaced without charge. The guarantee is limited to the replacement of the actuator only, as decided by our service department and no third party costs (e.g. labour costs for removal/ replacement, production down time, etc.) howsoever arising, will be entertained. Transport costs involved in the return and replacement are chargeable.



> The guarantee is only valid if the actuator has been installed, operated and maintained strictly in accordance with these instructions, and that the actuator has NOT been disassembled, self-repaired, incorrectly re-assembled, suffered damage caused by shocks or mal-operation, been supplied with inappropriate power supplies, used in conditions outside its specifications or working conditions, or suffered damage by practices not in accordance with sound engineering practice or common sense.



> Where a customer has failed to maintain his credit account (where applicable) within our terms, our guarantee will be suspended for and until the payments have been brought in line, and that this suspension will not prolong the guarantee period by the length of the delayed payment that caused the suspension of the guarantee.

REPLACEMENTS FOR 'FAULTY' ACTUATORS

> Goods must be examined immediately upon arrival and any loss or damage notified to us and the carrier (if applicable) in writing, within 24 hours of receipt, otherwise no claim will be entertained.

> Goods can not be returned without our prior consent.

> Where a 'failed' actuator can not be resolved by phone, any replacement actuator must be ordered using an official Purchase Order and the replacement actuator will be invoiced. Upon receipt and testing by us of the 'failed' actuator, the invoice for the replacement actuator will stand if we show that the 'failure' was caused by incorrect operation, connection, or non-adherence to these instructions, but will be credited should the manufacturer or his agent decide that the failure be due to faulty materials or workmanship. Where a returned 'failed' actuator works, and is returned to the customer, the replacement actuator can only be returned if it is in unused, prime, re-sellable condition.

EXTERNAL ELECTRICAL CONNECTORS - DIN PLUGS - SUPPLIED WITH THE J3C ACTUATOR

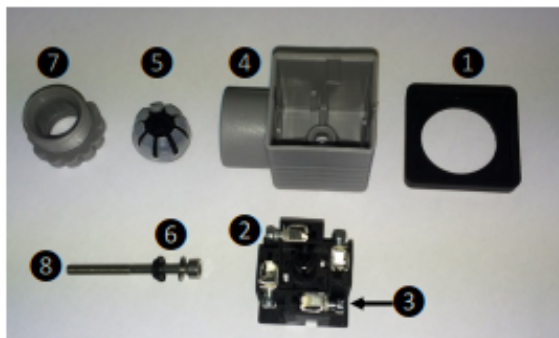

Item	Detail	LARGE CONNECTOR	
1	Gasket/ seal.	EN175301-803	
2	Terminal strip	Min cable Ø	Max cable Ø
3	Cable securing screws x 4	8 mm	10.5 mm
4	Housing		
5	Grommet	SMALL CONNECTOR	
6	Washer & seal	EN175301-803	
7	Gland nut	Min cable Ø	Max cable Ø
8	Securing screw	5 mm	6 mm

ELECTRICAL CONNECTORS (DIN Plugs) - no need to remove the J3C's cover to connect.



BEFORE connecting, ensure the voltage to be applied is within the range shown on the actuator's ID label. All connections are made using the supplied external DIN plugs. There is no need to remove the cover to connect electrically - **removing the cover may invalidate the warranty.**

Always check with the manufacturer's agent BEFORE removing the cover as they will give you information relevant to removing and replacing the J3C's cover. The grey plug is for the external power signals, the black plug is for volt free (dry contact) end of travel confirmation. The wiring of the DIN plugs is not the same - **always check the externally affixed wiring diagram BEFORE making the connections as damage caused by incorrect wiring is not covered by the warranty.**

ISO 9001:2015 Accredited Company

Tel: +44(0)1386 552369

Fax: +44(0)1386 554227

sales@allvalves.co.uk

www.allvalves.co.uk

Allvalves Online Ltd, Automation House, Unit 2, Pershore, WR10 2DF UK

WIRING DIAGRAMS



We recommend a fused independent supply for each actuator and it is very important that the power supply earth connection is made to prevent the current-free voltage on the non-live pin preventing the actuator working. This current-free voltage disappears as soon as the motor runs, but in non-earthed systems it has been identified as stopping the J3C from working.

The position confirmation switches are volt free and can have a different voltage applied than the power supply voltage e.g. 220V/1ph power supply, 24VDC for position confirmation. See notes at the bottom of this page regarding use of the volt free contacts (end of travel confirmation).

Function options with the J3C electric actuator:

J3C ON-OFF ELECTRIC ACTUATOR

Standard function is power open, power close. Stays put on loss of external power. Power remains on at all times.

J3C FAILSAFE ELECTRIC ACTUATOR (OPTION)

Fails to pre-set position on loss of external power.

Power open, power close, fails to pre-set 'safe' position on loss of external power using internal industrial trickle charged rechargeable NiCad battery. Can be set to fail close (NC or normally closed) or fail open (NO or normally open) on loss of external power. The failsafe electric actuator moves to the position command applied at the time external power is restored.

J3C ON-OFF & FAILSAFE WIRING (Same connection for either)

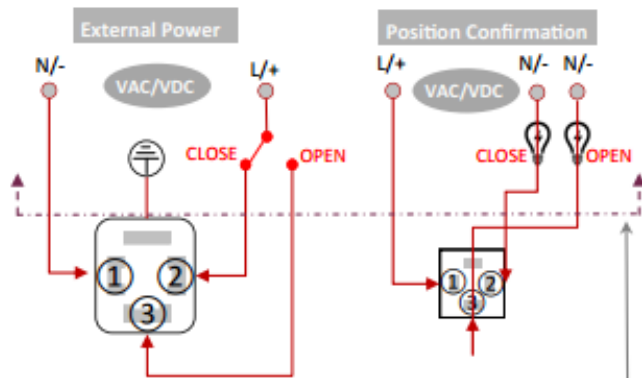

Note: Above line above is customer supplied

J3C MODULATING ELECTRIC ACTUATOR (OPTION)

Movement proportional to input signal

Power is applied continuously. Movement of valve actuator is then controlled by an internally fitted digital positioner and is proportional to changes supplied in an input control signal. This input signal is typically 0-10VDC, or 4-20mA. An output signal is supplied as standard providing closed loop control. Fails closed on loss of control signal (or see configuration options below), stays put on loss of external power.

Configuration options:

- 1) Closes on loss of control signal
- 2) Opens on loss of control signal
- 3) Stays put on loss of control signal

J3C MODULATING WIRING

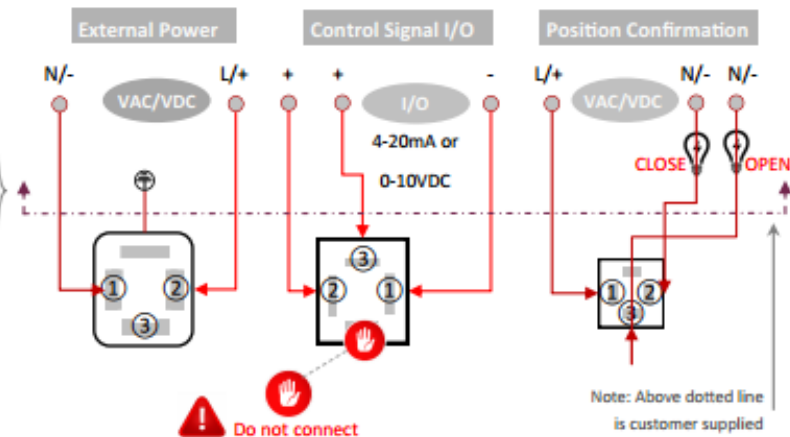

Note: Above dotted line is customer supplied

J3C FAILSAFE MODULATING ACTUATOR (OPTION)

Combination of failsafe & modulating kits above: Uses battery failsafe system and digital positioner plug and play function conversion kits to provide fail to safe position function on loss of external power in a modulating application.

IMPORTANT NOTES

EXTERNAL POWER SUPPLY/ COMMAND SIGNALS, AND POWER SUPPLY SIZING



The J3C electric actuator is designed to have continuous (not pulsed) external power applied at all times. It's internal thermostatic anti-condensation heater uses the external power to function, so switching off the power at end of travel switches this protection off. Damage caused by the effects of condensation is not covered by our warranty as we provide protection against it as standard. It is imperative that the power supply has sufficient capacity to drive the J3C electric actuator. Ensure that safety factor of 3 is used to cover inrush on start-up, and for increased draw over time as the brushed DC motor wears.



Another issue with using the end of travel confirmation signals to switch off the command signals is that as they are set around 5 degrees ahead of the final motor stop position (fully open, or fully closed), if used to switch off the power, the valve will not reach the final motor stop positions.

EXPLANATION OF THE DIFFERENT FUNCTION OPTIONS

Power to open, power to close: Stays put on mains power failure.

On receipt of a continuous power signal, the motor runs and via a planetary gearbox system, rotates the output shaft. The motor is stopped by internal cams, fitted to the output shaft, striking micro-switches which cuts power to the motor. When a subsequent continuous signal is received, the motor will turn in the opposite direction, reversing the direction of rotation of the output shaft. The actuator can be jog controlled by switching the power on to start and off to stop. Uniquely the on-off function can be changed by fitting the quick and easy to install function conversion kits, unique to J+J. This will create either a failsafe electric actuator using an industrial internal rechargeable battery, or a modulating electric actuator with a digital positioning system. Fitting both kits creates a failsafe modulating electric actuator.

Failsafe Function: Power open, power close, fails to pre-set position on power failure

Under normal operation the J3C failsafe electric actuator operates as an on-off actuator as above. Whilst power is applied, an internal industrial NiCad rechargeable battery is trickle charged to ensure it is fully charged. In the event of external power failure, the power source is switched by the BSR's PCB from external to internal and battery power is used to send the actuator to the pre-set 'safe' position, if not already in that position. Standard fail position is closed (fail closed or normally closed) but fail open (normally open) can be set. On resumption of external power, the actuator will move relative to the command signal being applied at the time power is restored.

Whilst the BSR from J+J can act as a 2 wire energise open, fail closed (as a solenoid) actuator, it is not designed to work this way, and care must be taken to ensure that there is no risk of condensation as the anti-condensation heater de-energised when external power is lost, and the energise or 'on' time must exceed the minimum time that particular model needs to replace the charge used in one movement, otherwise the battery will fully drain and may be damaged as a consequence.

This J+J designed system is called BSR (Battery 'Spring Return'). The BSR is a plug and play kit that can either be supplied installed and tested by us, or supplied as a simple to install and user friendly retro-fit kit.

Modulating Function: Movement of the actuator is proportional to an input signal via a digital positioner. Stays put on loss of external power.

The DPS from J+J is a self-calibrating and auto-adjusting Digital Positioning System supplied either installed by J+K or as a retro-fit option to the J3C range of reversible electric actuators to produce modulating functionality. The self-calibrating feature senses the motor stop closed position and sets the span from this position, and then auto-calibrates the range between open and closed for either 4-20mA or 0-10VDC control signals. In the J3C actuators, hunting has been virtually eliminated in the DPS and as soon as the actuator arrives at the required position relative to the input signal, it stops.

New to the J3C-S is digital magnetic position sensing whereby the output shaft position is digitally detected from a magnet affixed to the output shaft. The feedback from this digital magnetic system is compared to the input signal and if a difference exists, the DPS moves the motor in the direction required to eliminate the difference.

So, on receipt of a control input signal the actuator will move to the position relative to the input signal eg: using a 4-20mA signal, 4mA input signal fully closes the actuator, a 12mA signal sets the actuator at 45° and a 20mA signal fully opens the actuator. Each subsequent change of input signal will cause a corresponding change to the actuator position. This functionality can be reversed (reverse acting) if required. An output signal in the same form as the input signal is supplied as standard. In the case of control signal failure, the actuator will move to the closed position (or open if configured reverse acting). In the case of external power failure, the actuator will stay in the position it saw at the moment of power interruption, and will move to the signal it sees on resumption of external power.

Failsafe Modulating Function: Fails to pre-determined safe position on loss of control input signal or on loss of external power

J3C Modulating actuator fails to safe position on loss of power. By installing both the BSR and DPS function conversion kits, the J3 can provide failsafe modulating function in all models.

DIRECTION OF ROTATION & VISUAL POSITION INDICATION (2 Way valves)



VISUAL POSITION INDICATION (3 Way valves)

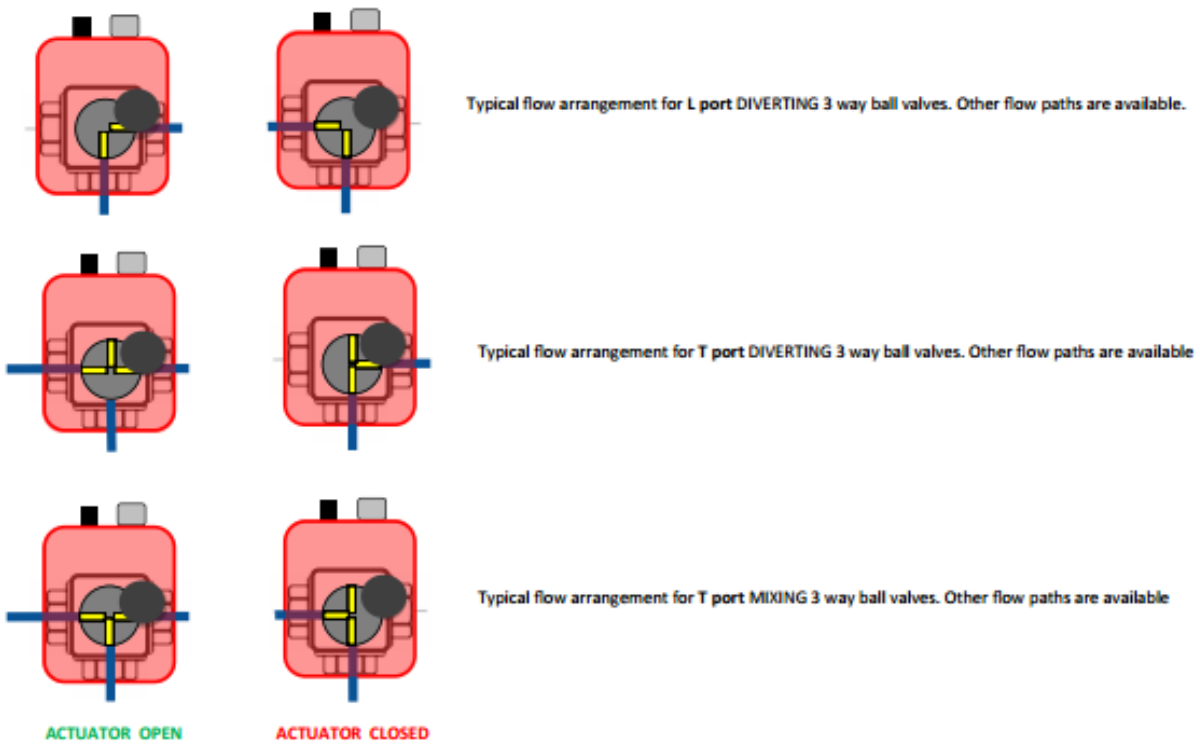

STANDARD WORKING QUADRANT

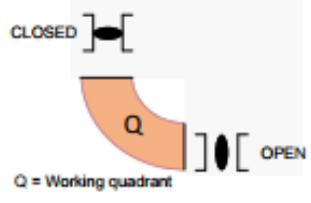

The J3C operates in the 0° to 90° quadrant shown in the diagram to the left. If the J3C is operated manually and returned into automatic mode whilst the actuator's indicator is outside the working quadrant, on the first automatic movement the J3C will rotate until it activates the correct finish position relative to the command signal - the actuator may rotate well beyond its normal 90° rotation to reset its position. This extended rotation is normal in these circumstances.

ADJUSTING THE WORKING QUADRANT

Should the required working angle be different to the standard factory set 0° to 90°, it is possible to adjust internal cams to extend the motor running time and therefore increase the working angle (say to 180° for bottom entry 3 way ball valves), but we recommend contacting a manufacturer's agent to secure advice on how to correctly and safely make these adjustments. Detailed instructions are available on request.

MULTI-COLOUR LED STATUS LIGHT





J3C without power, LED off







































































J3C with power, LED on

CONTINUOUS MULTI-COLOUR LED VISUAL FEEDBACK TO THE USER

The LED light is a standard feature in the J3C -and it serves 3 main functions:

- 1) When on/ lit, it advises users that the actuator has external power applied to it.
- 2) When continuously lit, the J3C is functional and awaits external commands to operate
- 3) If the LED blinks, there is a problem that is preventing the J3C from working. The sequence of the blinks gives the user an indication of the cause. See table below for the common LED sequences. (5,6 & 7)

Colours: **OPEN**  **CLOSED**  **Mid travel** 
(or opening) (or dosing)

No	Actuator Status	Time LED is lit	J3C-S LED Sequence
1	Actuator without external power	Continuous	         
2	Actuator with external power	Continuous	         
3	Actuator opening	200 mSecs	          OPEN
4	Actuator closing	200 mSecs	          CLOSED
5	Torque limiter activated when opening	200 mSecs	         
6	Torque limiter activated when closing	200 mSecs	         
7	Actuator in manual mode	200 mSecs	         

MANUAL OVERRIDE

1 Select 'MAN'



2 Turn by hand to operate, local indicator shows position



DO NOT TURN THE J3C's HAND WHEEL WITHOUT FIRST SELECTING 'MAN', OR CARRY THE J3C BY THE HAND WHEEL, OTHERWISE IRREPARABLE DAMAGE WILL BE CAUSED TO THE ACTUATOR'S GEARBOX. SUCH DAMAGE WILL NOT BE COVERED BY THE WARRANTY

3

Select 'AUTO' to return to automatic operation



Selecting 'MAN' by moving the selector lever from 'AUTO' disengages the output drive, but the motor continues to run. After a short time the J3C realises the end of travel cam has not been reached, the motor is running with no load which indicates the valve is not jammed—therefore the actuator is in manual mode. The motor then stops and the LED sequence 7 above starts to advise the user that the J3C is in 'MAN'.

As a safety measure, the J3C will not respond to external command signals whilst in manual mode. On returning the selector lever to 'AUTO' the LED returns to being solidly lit, and the actuator will respect whatever command signal is being applied at the time the selector lever is returned to 'AUTO'.

ELECTRONIC TORQUE LIMITER

The J3C has an electronic torque limiter (ETL) to protect the internal gears from mechanical damage should the valve become blocked or jammed. The ETL constantly measures the motor current and using a complex algorithm in the on-board chip, senses the rise in motor current seen at the point of blockage and cuts the power to the motor. At this point it blinks the LED with sequence 5 or 6 in the table above, and also sends the actuator in the reverse direction of the block to relax the gearbox to allow the manual override to be used if required.

The ETL is not designed to be used where it is being constantly activated (for example as a mechanical stop), it is designed as a safety device. If the ETL is activating frequently it indicates that either there is a problem with the valve, or the actuator is undersized for the application. Over use will eventually cause the ETL system to fail and on the next over-torque occasion, the actuator will fail. **This failure is not covered by the manufacturers' warranty.**

ISO 9001:2015 Accredited Company

Tel: +44(0)1386 552369

Fax: +44(0)1386 554227

sales@allvalves.co.uk

www.allvalves.co.uk

Allvalves Online Ltd, Automation House, Unit 2, Pershore, WR10 2DF UK

MOUNTING THE J3C ACTUATOR TO 1/4 TURN VALVES

J3C Actuators have mounting facilities in accordance with ISO:5211 and DIN:3337 allowing them, in many cases, to mount directly onto similarly compliant valves without the need for a mounting kit (bracket and drive adaptor/ connector). The main advantages of direct mounting the actuators is to greatly assist in ensuring concentricity of the actuator output drive with the valve stem which eliminates side loadings (which result in increased wear on the valve stem and seals), reducing the effects of backlash in the drive train as there are fewer parts connected, and allowing valves to be part dismantled for installation into the pipe without disturbing the valve to actuator connection.



The drive being inserted into the actuator's female output drive must NOT be longer than the maximum depth of the female drive when the assembly is bolted together. Resulting damage to the actuator and assembled components due to this assembly error will not be covered by our warranty.

J3C Model	Maximum torque Nm	Run & Reseat torque Nm	ISO5211	Output star drive x depth	Optional star output	Special execution
20	25	20	F03, F04 & F05	14 x 15	9, 11	
35	38	35	F03, F04 & F05	14 x 15	11	F07 x 17 star
55	60	55	F05 & F07	17 x 19	14, 11	
85	90	85	F05 & F07	17 x 19	14	

WEATHERPROOF RATING



The J3C electric actuators have an ingress protection rating of IP67, which gives them total protection against almost all kinds of weather and allows the actuator to be submerged under less than 1m of water for no more than 30 minutes. **However, it cannot withstand being hosed down or pressure washed, or deluged in water.**

If the J3C is to be exposed to hosing down or pressure washing, a plastic bag must be put over the J3C actuator to protect it from the direct hosing down. Even in these circumstances, do not pressure wash the plastic bag close up.

RECYCLE AT END OF LIFE



Although electric actuators are currently excluded from mandatory WEEE recycling, J+J is committed to the protection of the environment.

Please remember at end of life to dispose of responsibly and if the facilities are available, recycle.